



AUTOMATION OF ANIMAL, FAULT DETECTION IN RAILWAY TRACK USING PLC

M. Balamurugan*, T. Parthinban*, V. Killivalavan
& S. Manoj Kumar****

* Assistant Professor, Department of EEE, Excel College of Engineering & Technology, Namakkal, Tamilnadu

** UG Scholar, Department of EEE, Excel College of Engineering & Technology, Namakkal, Tamilnadu

Abstract:

Presently in the real time world, commuters are using different types of transport facilities such as flights, trains, buses, cars etc. But majority of the public in our country prefer traveling in trains. The reason may be the comforts available for long journeys and relatively lesser travelling charges. Though the railways has implemented many safety standards for the safe journey, still one can witness some rail accidents and leading to the loss of many precious lives and loss of property. Some of the major reasons for rail accidents are due to the faults on the rail. At present our railways are using manual methods of fault detection through human inspectors. This work is an attempt to develop an advanced automatic PLC based fault detection technology in railway network to overcome the above problems. The proposed automatic control system makes use of vibration monitoring sensor and ultrasonic sensors to detect the faults occur in the railway track. The hardware components such as PIC16F877A microcontroller, Programmable logic controller (PLC) and GSM are used as advanced controlling and communication elements of automatic fault detection system.

Index Terms: Low Cost Automation, LC, Microcontroller, GSM & IR Camera

1. Introduction:

The basic objective of this project is to develop a breakage detection of railway tracks using programmable logic control (PLC) which is used to find the detection of breakage in the railway track. The Indian railway (IR) network today has track length of 1,15,000 kilometers over a route of 65,000 kilometers and 7,500 stations. It is the fourth largest railway network in the world exceeded only by those of the United States, Russia and China. In 2011, IR carried over 8,900 million passengers' annually or more than 24 million passengers daily and 2.8 million tons of freight daily. Despite boasting of such impressive statistics, the Indian rail network is still on the growth trajectory trying to fuel the economic needs of our nation. Though rail transport in India is growing at a rapid pace, the associated safety infrastructures are not up to international standards. To demonstrate the gravity of the problem, official statistics say that there have been 14 accidents in 2011, 15 accidents in 2012. On further analysis of the factors that cause these rail accidents, recent statistics reveal that approximately 90% are due to cracks on the rails either due to natural causes (like high expansion due to heat). The present work is focused on bringing down the accident rate by automatically detecting the breakage/s on the tracks.

2. Hardware Description:

Ultrasonic Sensor:

Ultrasonic sensors emit short, high-frequency sound pulses at regular intervals. These propagate in the air at the velocity of sound. If they strike an object, then they are reflected back as echo signals to the sensor, which itself computes the distance to the target based on the time-span between emitting the signal and receiving the echo. As the distance to an object is determined by measuring the time of flight and not by the

intensity of the sound. Ultrasonic sensors are used for material testing (to detect cracks, air bubbles, and other flaws in the products), Object detection, position detection, ultrasonic mouse, etc. measuring the time of flight and not by the intensity of the sound. Ultrasonic sensors are used for material testing (to detect cracks, air bubbles, and other flaws in the products), Object detection, position detection, ultrasonic mouse, etc.

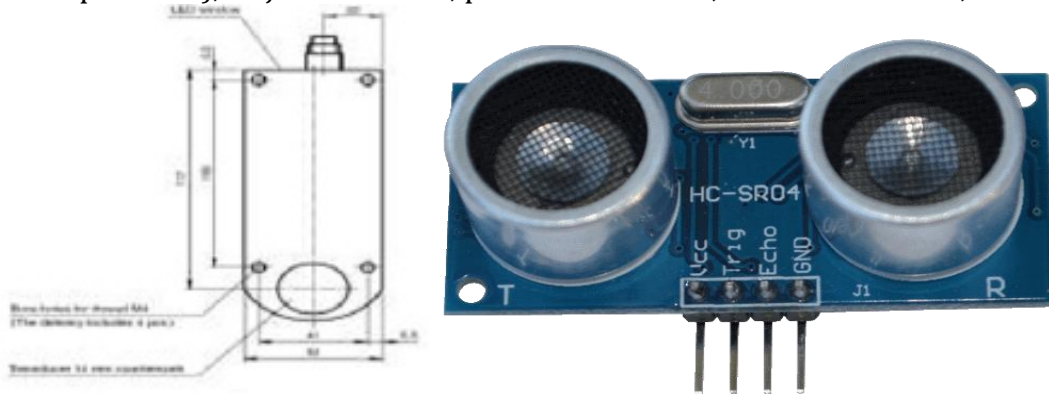

Figure 1: Ultrasonic Sensor

Features of Ultrasonic Sensor:

- Current output 4 mA to 20 mA.
- Serial Interfaces.
- Temperature compensation.
- Reverse polarity protection.
- Programmable with ULTRA 3000.

Vibration Sensor:

Vibration sensor is a device that uses the piezoelectric effect, to measure changes in pressure, acceleration, strain or force by converting them to an electrical charge. Vibration sensor based on the piezoelectric effect Change in resistance due to the force acting on it and converts it into 4 - 20 mA. They're measuring differences in oscillation and detect the vibration created on the surface.

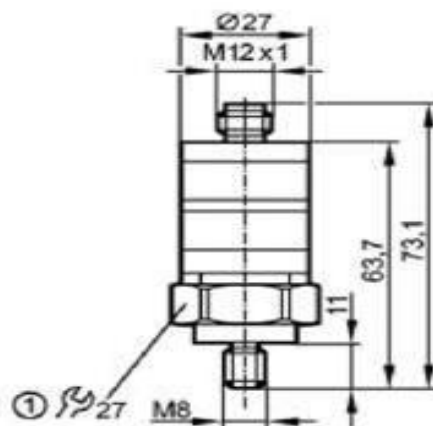

Figure 2: Vibration Sensor

Characteristics of vibration sensor

- Vibration Monitor.
- Measuring Range RMS: 0 to 25mm.
- Switching outputs: Normally Closed and Analogue 4 to 20ma.

Indra Control L20 PLC:



Figure 3: PLC Kit

The Indra Control L20 is a modular control. It combines the benefits of a compact small control with a standardized I/O system on the basis of terminal technology. It is a hardware platform that can be used for PLC applications. It provides onboard interfaces, e. g. high-speed inputs and outputs (8 each) and communication interfaces, such as Ethernet, PROFIBUS and RS232. The locally available I/O units can be extended by the Rexroth Inline I/O system, just by simply mounting the components side by side. Application programs, including runtime, are completely stored to an easily accessible standardized Compact Flash medium. Operating elements and interfaces are arranged on the front. The eight-digit display with four operator keys, the Reset button with light-emitting diode, the RS232 interface, and the receptacle for the Compact Flash card are provided to the left of the unit. Further interfaces (Ethernet, PROFIBUS DP) are located in the central section of the unit. The terminals for digital inputs and outputs (eight each) and the voltage supply connectors are arranged to the right of the unit.

Advantages of PLC:

- Programming a PLC is easier than wiring the relay control panel.
- PLC can be reprogrammed. Conventional controls must be rewired and are often scrapped instead.
- PLC takes less floor space than relay control panels.
- A PLC has facility for extensive input/output arrangements.
- Maintenance of the PLC is easier, and reliability is greater.
- PLC can be connected to the plant computer systems more easily than a relay.
- PLC has very few hardware failures compared to electromechanical relay.

3. Related Work:

A literature survey has been carried out in the present investigation to select the problems which are being faced by the railways network. The work has been narrowed down in detecting the breakage in the Railway tracks which are causing accidents leading to loss of lives and property. The present work is intended to propose solutions to reduce the occurrence of tragic accidents. Raghupathy et.al [1] in their work have designed a system based on ultrasonic waves which would prevent the train accidents due to derailment of tracks, unmanned railway crossing and head on collision. Stefan et al, [2] have used the Eddy current sensors to detect the fault in track. The sensors are mounted 100mm above the rail head of the train bogie. This sensor monitors the railway track and detects the breakage/s in the track. Ramesh et al, [3] have suggested the detection of cracks and derailments in rails which can be done by ultrasonic waves or sensor. AnjaliBissa et al, [4] have used vibration sensors and Zigbee technology using microcontroller. To detect the faults in the track or when a running train is detected in front of the standing train, the sensors detects and sound an alarm which is fitted in the

operating room in the engine P. Kiran Kumar, B.S. Shiva Shankara, [5] have used vibration and ultrasonic sensors to suggest automation of fault detects on the track. From the above literature survey we conclude that PLCs are widely used in detection purpose of railway track.

4. Working Methodology:

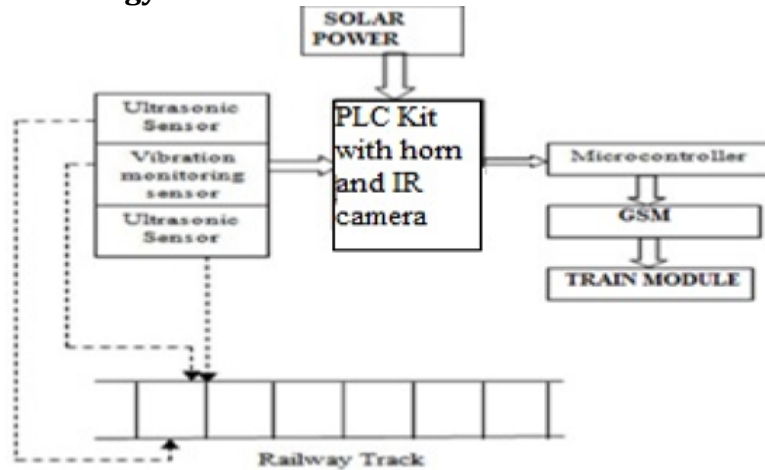

Figure 4: Block Diagram of Automated animal and fault Detection System

The figure 4 shows block diagram of the automated railway track fault detection system. In the system one vibration monitoring sensor and two ultrasonic sensors, are used to detect the faults in the railway track. The ultrasonic sensors are located as ZigZag manner and the vibration monitoring sensors are fixed at the along with the sensor. The vibration monitoring sensor and two ultrasonic sensors are connected as inputs to the PLC and the microcontroller is connected to the output of the PLC, then the GSM is connected to the microcontroller.

When the train is 3kms away from the obstacle to hit. If any breakage/s, faults or obstacle present in the railway track, the vibration monitoring sensor senses the defects in terms of vibration fluctuation and ultrasonic sensor detects the position from echo signal and sends the signal to the PLC. At the same time the PLC sends the predicted defects information to the microcontroller. Here the microcontroller trigger the IR CAMERA to take the picture of obstacle present there and finally conveys the received information from the PLC and IR CAMERA to the GSM Module. GSM module sends the information via SMS to the moving train module (nearby train) and the traffic control room of the nearest railway station. The nearby train driver receives the information obstacle picture and fault in tracks through train user interface software. After locating GPS location, driver gives the horn command in module; this signal is again passed to the PLC kit which is in the track via GSM communication for blow the horn present in track, now the train collision with the animals can be present in advance.

5. Ladder Diagram:

PLC programs are typically written in a special application on a personal computer, and then downloaded by a direct-connection cable or over a network to the PLC. The program is stored in the PLC either in battery-backed-up RAM or some other non-volatile flash memory. Often, a single PLC can be programmed to replace thousands of relays.

Ladder logic is a programming language that represents a program by a graphical diagram based on the circuit diagrams of relay logic hardware. It was primarily used to develop software for programmable logic controllers (PLCs) used in

industrial control applications. The name is based on the observation that programs in this language resemble ladders, with two vertical rails and a series of horizontal rungs between them. Figure 5 shows ladder logic.

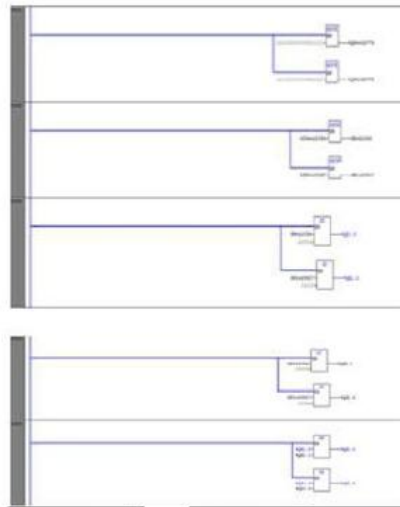

Figure 7: Ladder Diagram

The PLC ladder logic diagram is as shown in the figure 7. %QX1.0, %QX1.1, %QX1.2, %QX1.3, %QX1.4, %QX1.5, %QX2.0, %QX2.1, %QX2.2, %QX2.3, %QX2.4 are the digital outputs. %IW4 and %IW6 are refers as analog inputs of the system and %QW4 and %QW6 are refers as analog outputs of the system. To operate the system in analog modes. The analog mode has some standard binary values, that standard binary value has to assign in the program and that binary values has to convert in to word. After conversion the analog mode is ready to operate in the program.

%IW4 and %IW6 are the ultrasonic sensors inputs connected to the PLC. RW and RW1 are the output coming from ultrasonic sensors that RW and RW1 outputs are given as input to the greater functional block (GT) and lesser functional block (LT). The RW and RW1 will compared with the assigned alue in the greater functional block. If the RW and RW1 is greater than the assigned value then %QX1.0 and %QX1.3 will glow the LED, then the track is said to be fault. If it is not greater than the assigned value then %QX1.0 and %QX1.3 will not prompt the LED and it will check for the lesser condition. If the RW and RW1 are lesser than the assigned value, then the %QX1.1 and %QX1.4 will prompt the LED then the track is said to be fault. If it is not lesser than the assigned value then the %QX1.1 and %QX1.4 will not prompt the LED. The GT and LT functional block outputs are connected to OR gate then check for the conditions: If any one of the GT and LT functional block output are 1 then the track has fault. If both the GT and LT the functional block output are 0's then the track is in normal conditioned.

6. Conclusion:

The Proposed work is an advanced alternative solution to replace the manual method of fault detection of railway track with a PLC based automated animal and fault detection system. This system completely eliminates the human intervention for detecting animal and faults. It provides a high speed detection system that automatically communicates the predicted railway track defects information immediately to the concerned train at the time and railway traffic control room by using GSM system; hence this will reduce the accident rates and loss of precious life. The PLC used as a controller in this system, makes the entire system as a user friendly and highly reliable that carries out control functions of many types and levels of complexity.

7. References:

1. Raghupatty, Pranab, Dineshkumar, Bharath," Automatic Rail Detection Using Ultrasonic Detector", International Conference on Modern Trends in Signal Processing, 2012.
2. Stefan et al, "HMM Based Segmentation of Continuous Eddy Current Sensor signal", 11th International IEEE conference on Intelligent transportation systems, china, vol.13, Page 760-765, 15 Dec 2008
3. Selvamraju et al, "Robust Railway Crack Detection (RRCDS) Using LED-LDR Assembly", IEEE published, Page 477- 482, 2012.
4. Anjali Bissal et al, "Train Collision Avoidance System Using Sensors and Zigbee Technology", international journal of research in engineering and advanced technology, March 2013.